

Multi Purpose DP2 Support Vessel "Zwerver II"



Dimensions:	
Length o.a. :	35.10 m
Breadth mld. :	15.00 m, excluding fendering
Depth ½ L :	4.07 m
Draught min. :	2.60 m
Draught max. :	3.00 m
Free deck space :	300.00 m ²
Max. deck load :	10.00 t/m ²

Tank capacities:	
Fuel oil :	195.00 m ³
Fresh water :	58.00 m ³
Lub oil :	8.00 m ³
Hydraulic oil :	8.00 m ³
Dirty oil :	9.20 m ³
Grey water :	22.00 m ³

Propulsion system:	
Main engines :	3 x Mitsubishi S12R-MPTAW
Total output :	2.820 kW
Gearboxes :	2 x Reintjes WAF 665
Propulsion :	2 x f.p. propellers in nozzles
	2 x Ø 2000 mm
	1 x ZF Z-drive WM-6111 Ø 1750 mm
Bow thrusters :	2 x ZF Z-drive AT-4011, 400 kW each

Performances:	
Speed :	Approx. 11.5 knots
Bollard Pull :	Approx. 60,3 T

Auxiliary systems:	
Generator sets :	2 x Mitsubishi 6D24TC 204 kVA
	Both sets deliver 230/400 V – 50 Hz
Hydraulic power :	2 x Mitsubishi S6R-MPTAW – 605 kW each
Transfer pumps :	Fuel & fresh water 60 m ³ /hr, including
	Transfer hoses on reels and indicators
Air compressor :	Atlas-Copco GA 22+FF, 4000 ltr/min, with
	connections on deck/store/engine room
Fresh water maker:	5m ³ /24 hr

DP-2 equipment:
NAVIS NAV DP-4011, Cyscan Laser Radar MK4

Classification:
Bureau Veritas I Mach Tug Unrestricted Navigation ALM AUT-UMS –
Dynapos AM/AT-R Ice Class 1D

Deck equipment:	
Offshore Access System :	Passive heave compensated gangway
	Draftec / Uptime LGAP 1420
Length :	12-14 m
Deck crane fore :	Installed midships, working up to Hs = 1,6 m
	HS Marine AKC-370 HE3. Lifting 10 T @ 20 m
Winch :	13 T Single fall, 80 mtr wire.
Deck crane aft :	Lagendijk LKB 510 T3-T1. Lifting 11 T @ 23 m
CT-winch :	20 T lifting single fall, 130 mtr wire
	40 T double fall
AHC winch:	2,5 T lifting in AHC Mode, installed on 2nd jib.
(optional)	1 T Man-riding
Anchor-handling winch :	Wire capacity 1000 m x Ø 64 mm; 200 T pull,
	250 T hold capacity
Towing winch :	Wire capacity 1000 m x Ø 48 mm; 100 T pull,
	200 T hold capacity
Tugger winches/4-pt mooring :	4 x 450 m x Ø 24 mm; 15 T pull, 30 T Hold
Towing pins/shark jaws fore :	1 set 200 T SWL
Guide pins fore/aft :	2 x 2 pcs hydraulically controlled; 150 T SWL
Towing pins/shark jaws aft :	1 set 200 T SWL
Bow roller :	8000 x 2000 mm; 250 T SWL
Stern roller :	4000 x 1300 mm; 250 T SWL
Spud poles :	2 x Ø 600 mm, 15 m length
Moonpool :	2000 x 2000 mm
Bow-door :	Hydraulically operated bowdoor, rises deck
	level with 1000 mm to avoid seawater/swell flushing
	deck.

Container fittings flush in deck, 4-pt mooring available at request.

Accommodation:
Comfortable accommodation for 17 persons in 9 cabins. All cabins, galley, office and wheelhouse are heated, air conditioned, VSAT and SatTV.

Large office below bridge level for survey-/OSPT/client-reps.

Additional Accommodation: (option)
2 x 2-pax TLQ's, high standard (same as vessel cabins), comfortable, heated and air conditioned, equipped with sanitary spaces, classed without restrictions. To be positioned behind deckhouse with fixed connections to power circuit/sanitary circuit/internet/SatTV and so on.

Navigational equipment: equipped for area A3

Suitable projects for this vessel

Wind farm-/Renewable Energy projects, vessel can act as:

- Walk-to-Work vessel/Offshore Access/Maintenance support vessel for turbines, platforms and other floating equipment;
- Diving support vessel on 4-pt mooring or on DP2;
- General support vessel for installation of turbines/floating objects;
- Anchor-handling vessel/Towing tug;
- Pre-Lay Grapple Runs (with low and high tow-forces);
- Cable-/Pipe lay support vessel;
- Anchor pre-installation vessel > 200 T winch pull;
- Supply vessel;
- Survey-/ROV support vessel;
- Cable burial/trenching;
- Cable inspections;
- Pipeline inspections;
- Mattress installations Pre-lay/Post-lay;
- CBT/Vibrocore operations;
- Beach pull operations.



Offshore construction projects, vessel can act as:

- Walk-to-Work vessel/Offshore Access/Maintenance support vessel for turbines, platforms, SPM buoys and other floating equipment;
- Diving support vessel on 4-pt mooring or on DP2;
- General support vessel;
- Anchor-handling vessel/Towing tug/push-pull tug;
- Cable-/Pipe lay support vessel;
- SPM-buoy installation vessel;
- Anchor pre-installation vessel > 200 T winch pull;
- Supply vessel;
- Hose handling/maintenance vessel;
- Survey-/ROV support vessel;
- Cable burial/trenching;
- Cable inspections;
- Pipeline inspections;
- Mattress installations Pre-lay/Post-lay;
- CBT/Vibrocore operations;
- Beach pull operations.



References:

An extensive reference list of dredging- and marine construction companies shows the many years of experience in the offshore industry. Examples are:

- Allseas Marine Contractors
- DEME NV
- Van Oord Dredging & Marine Contractors BV
- Van Oord Offshore & Marine Contractors BV
- Van Oord Offshore Wind Projects BV
- Boskalis BV
- Mc Dermott International
- Saipem SA
- Tideway Marine & Offshore Contractors BV
- Jan de Nul NV
- Prysmian Powerlink Services Ltd.
- C-Ventus Offshore Windfarm Services BV
- Modus Seabed Intervention Ltd.



Overview/drawings



VAN STREE
OFFSHORE

Front view Gangway - SB side landing position

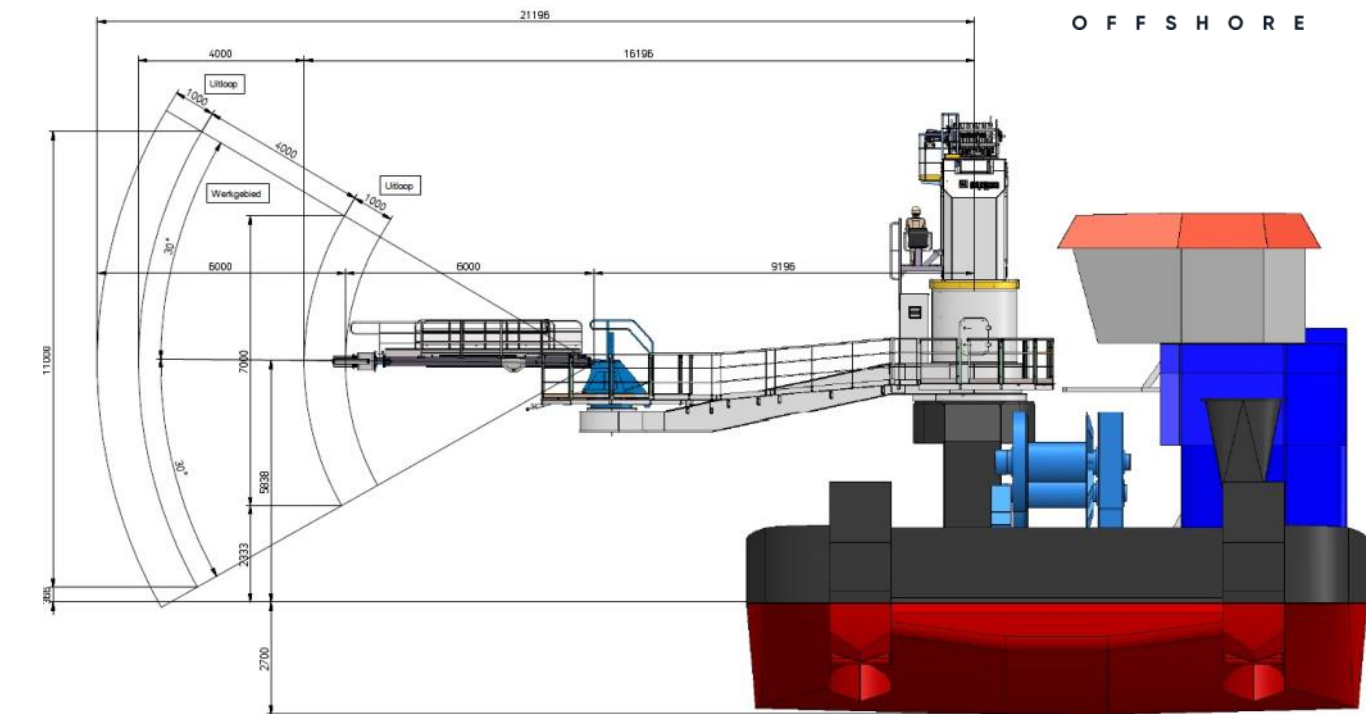

Deck view

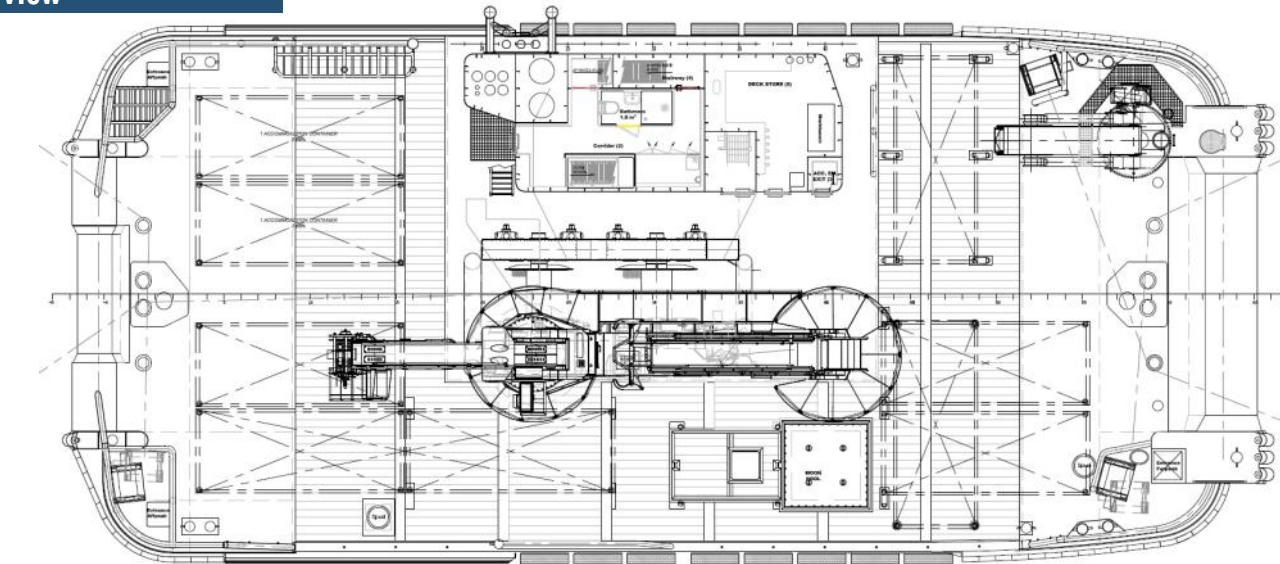

Tank Top

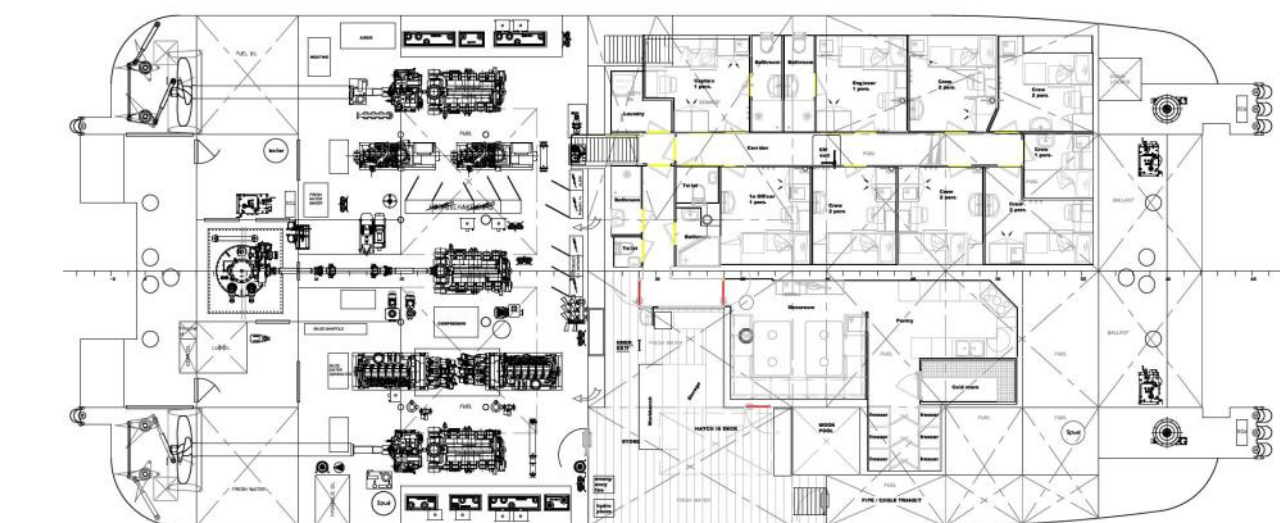

Crane drawings / diagrams

Walk-to-Work - DP2 - Offshore Support

“ZWERVER II”
Multi Purpose DP2 Support Vessel
WALK-TO-WORK



**Lifting capacities Midships crane
Draftec LKB 510 T3-T1**

Distance from base	Fixed hook	CT-winch, Single Fall	CT-winch, Double Fall	2nd Jib (AHC) (Optional)
6.50 m	50.000 Kg	20.000 Kg	40.000 Kg	-
8.00 m	45.000 Kg	20.000 Kg	40.000 Kg	5.000 Kg (2.500 Kg)
12.75 m	22.000 Kg	20.000 Kg	20.000 Kg	5.000 Kg (2.500 Kg)
16.30 m	14.600 Kg	14.600 Kg	14.600 Kg	5.000 Kg (2.500 Kg)
19.80 m	12.000 Kg	12.000 Kg	12.000 Kg	5.000 Kg (2.500 Kg)
22.90 m	10.300 Kg	10.300 Kg	10.300 Kg	5.000 Kg (2.500 Kg)
25.00 m	-	-	-	5.000 Kg (2.500 Kg)
29.50 m	-	-	-	3.500 Kg (2.500 Kg)
31.70 m	-	-	-	2.500 Kg (850 Kg)

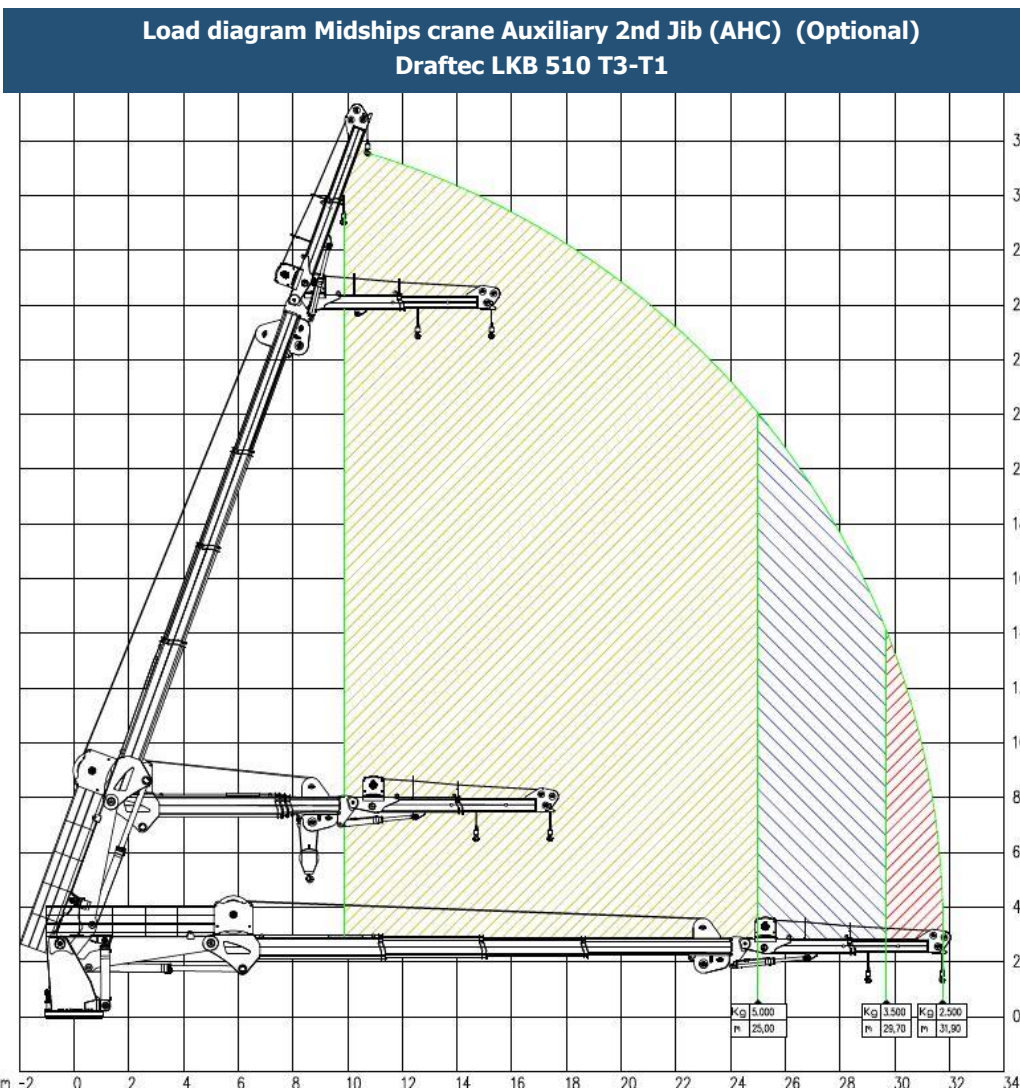
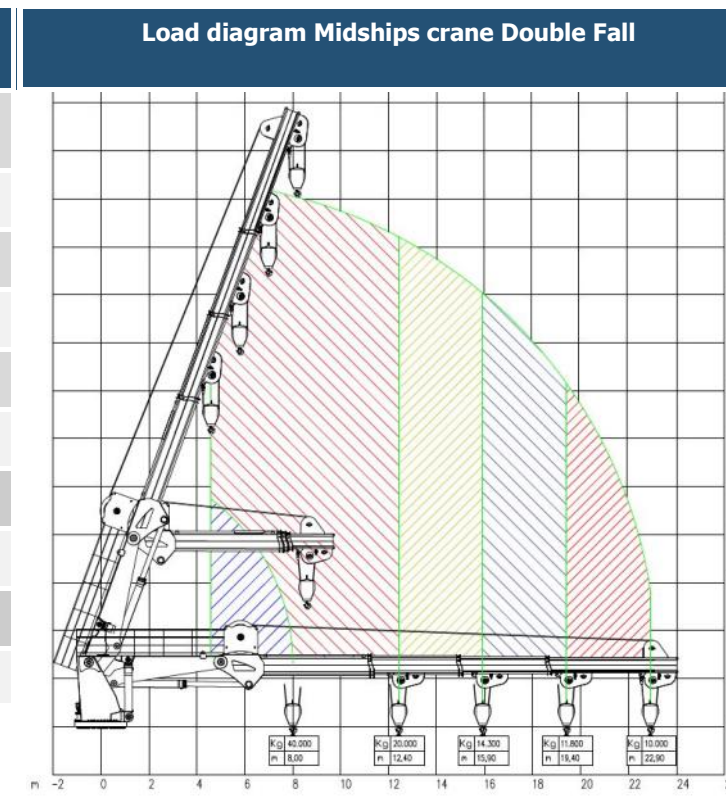

**Lifting capacities Front crane
HS Marine AKC 370/20 HE3**

Distance from Base	13 T winch	Fixed Hook
5.74 m	13.000 Kg	42.750 Kg
9.77 m	13.000 Kg	25.000 Kg
12.80 m	13.000 Kg	17.450 Kg
16.25 m	13.000 Kg	12.800 Kg
20.00 m	9.720 Kg	10.000 Kg

VAN STEE OFFSHORE
Nieuwe Visserhaven 13 • 8861 NX Harlingen • The Netherlands
Tel. +31 (0) 653663292
info@vansteeoffshore.com • www.vansteeoffshore.com